

Tech Guide

Jeep Grand Cherokee SRT MY11-22 TVS2650 Supercharger

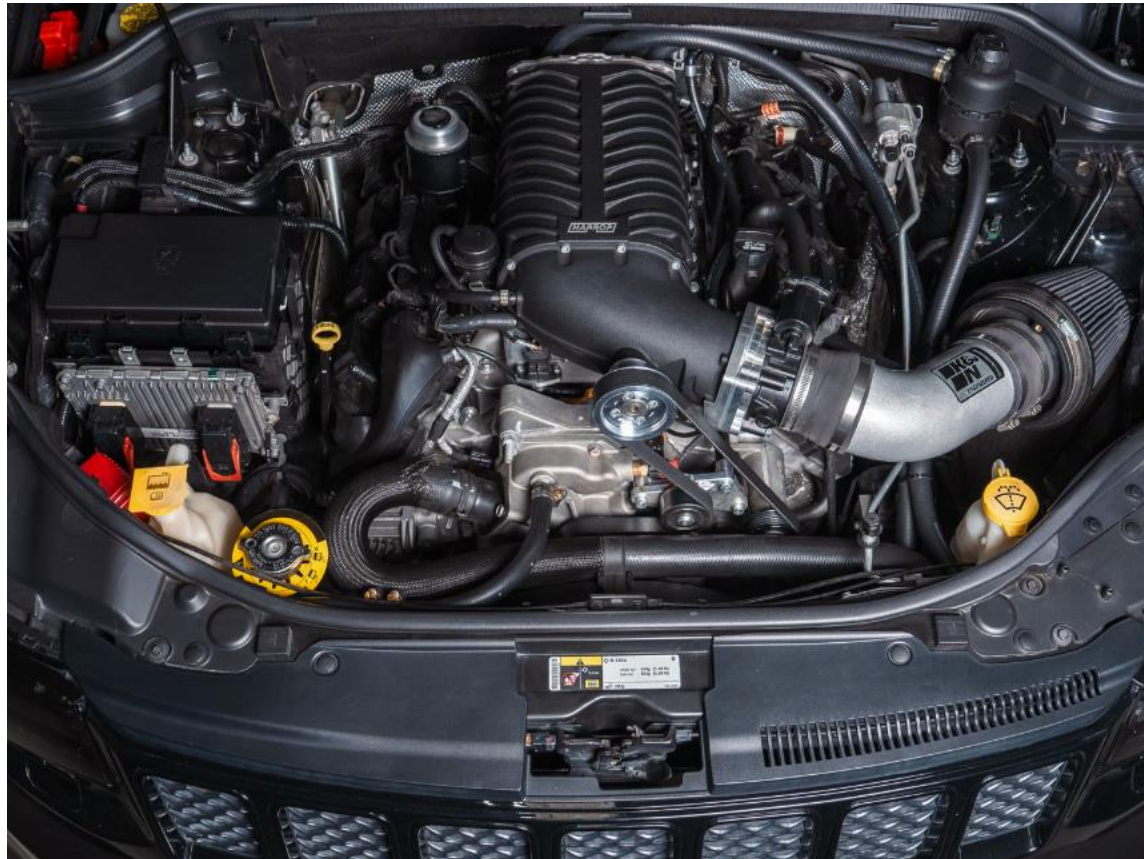

Harrop Engineering develops and manufactures premium supercharger kits for customers globally. Since 1955 Harrop have successfully designed and manufactured components for OEM's, Motorsport Teams, Car Builders and Enthusiasts. Harrop Engineering Australia and USA is certified to ISO 9001 standards with superior quality, performance and vehicle integration the foundation of Harrop Performance Products.



*Shown with aftermarket intake and filter

13/02/2026

ENGINEERING PERFORMANCE SINCE 1955

1

Tech Guide

Jeep Grand Cherokee SRT MY11-22 TVS2650 Supercharger



Key Features

- Complete vehicle kit for installation
- No other modifications required
- High efficiency TVS2650 Mk2 supercharger technology
- Optional TVS2650 Mk2 CNC Race Ported (RP) supercharger
- Bypass valve integrated for increased efficiency at low engine loads
- High density double pass intercooler core
- High flow replacement fuel injectors DW 17U-00-0050-8
- 2 bar MAP sensor Mopar 05033224AB
- Vehicle retains all OEM functionality
- Retains OEM airbox
- 1/8" BSPT boost referenced port available
- Supercharger pulleys 70-90mm available

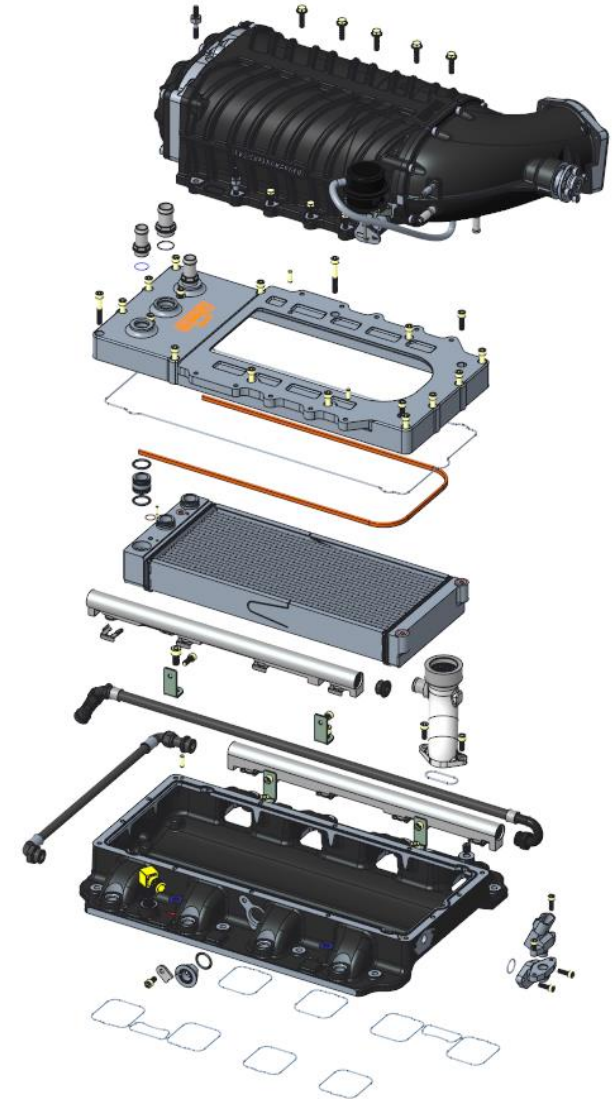

Assembly Layout

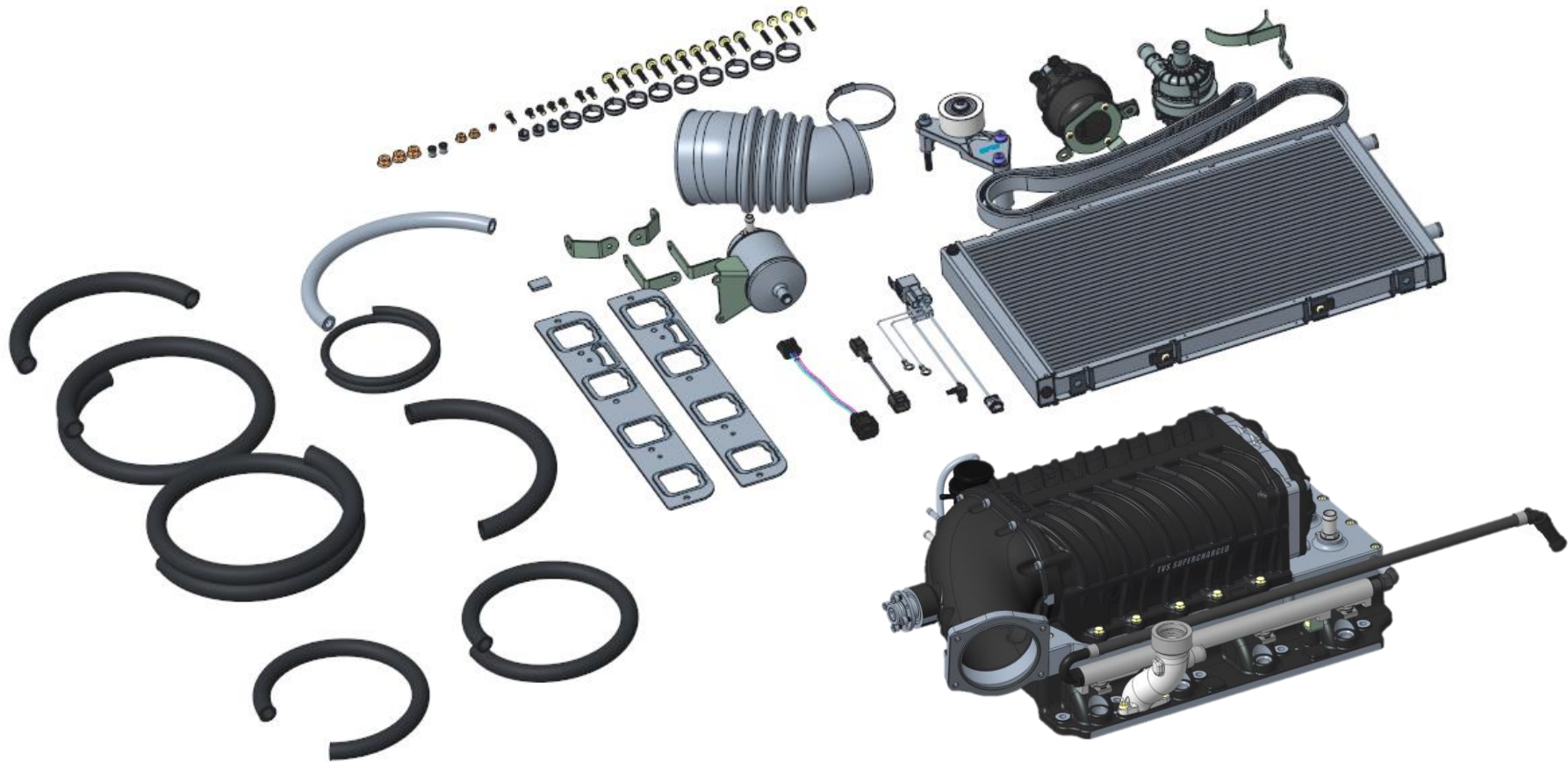

Part Numbers

Supercharger Kit	Kit Number
Jeep Grand Cherokee SRT Mk2 TVS2650	99-KSM94K65
Jeep Grand Cherokee SRT Mk2 RP-CNC TVS2650	99-KSM95K65

Supercharger Pulley	Belt*
99-PLY16759 90mm	65-6PK2605
99-PLY16375 85mm	65-6PK2605
99-PLY16374 80mm	65-6PK2620
99-PLY15785 75mm	65-6PK2620
99-PLY16373 70mm	65-6PK2635

*Belts for vehicles with electric power steering



Performance Data

Vehicle details	Peak power	Peak torque	Supercharger pulley	Peak boost
1-7/8" headers into 3" exhaust 221/227 cam package Aftermarket pod filter	323 kW (433 hp)	583 Nm (430 ft-lbs)	NA	NA
As above with Harrop 2650 supercharger	401 kW (538 hp) +24%	710 Nm (524 ft-lbs) +22%	90mm	~6 PSI

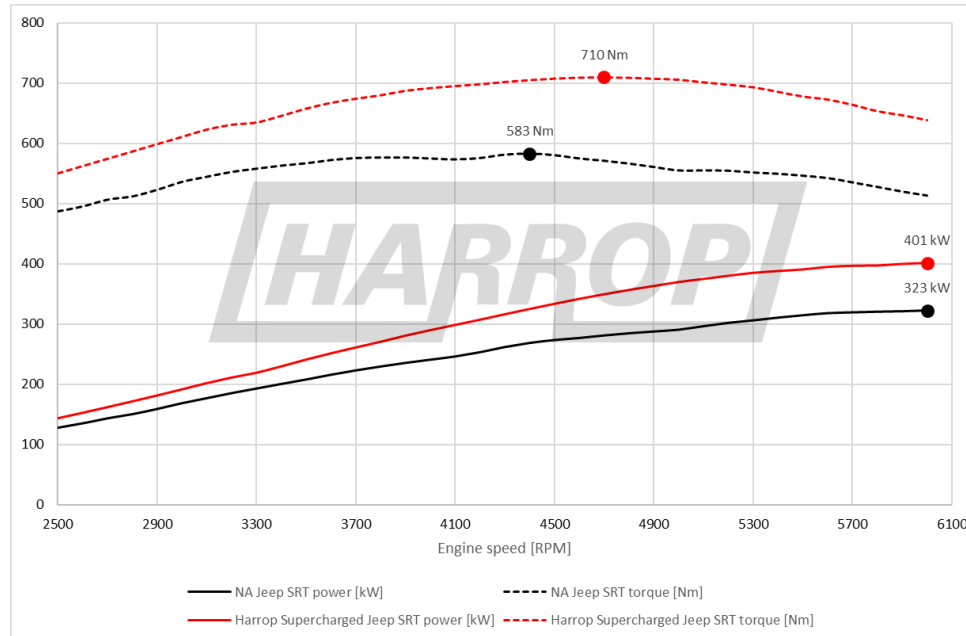

2017 Jeep Grand Cherokee SRT with 8 speed auto

Measured on the Harrop Dynapack dynamometer on 98 RON/93 AKI fuel at 28°C ambient temp

Performance results will vary subject to variable factors such as weather, dyno type, fuel quality, calibration, engine and vehicle condition and configuration.