



Installation Guide

H2650i

The Harrop LSA-H250i Supercharger Tuner kit has been developed for GM LSA engine found in HSV, ZL1 and CTS-V models. This document is meant only as a guide, as any vehicle modification should be completed by a certified technician who has the relevant experience and equipment to be competent of a safe and effective supercharger installation.



May 2026 - Rev 0

<u>Contents</u>	<u>Page</u>
1) OEM Supercharger removal	3
2) Prepare H2650i Supercharger	4
3) Fitting Supercharger Assembly	5
4) Boost control solenoid	6
5) Bypass vacuum actuator line	7
6) Throttle body adaptor	8
7) Pulley installation	9

References to left and right in the instructions are made to the vehicles side and NOT the installer

1) Removing OEM Supercharger

- a. Remove negative terminal from battery
- b. Remove all electrical connectors from manifold / inlet (injectors, MAP sensors, MAP, throttle body, etc)
- c. Remove inlet air tube
- d. Remove the original supercharger manifold assemble
- e. Replace the 6 bolts in the valley plate as shown with the supplied M8x25 button head screws. Torque to 25Nm

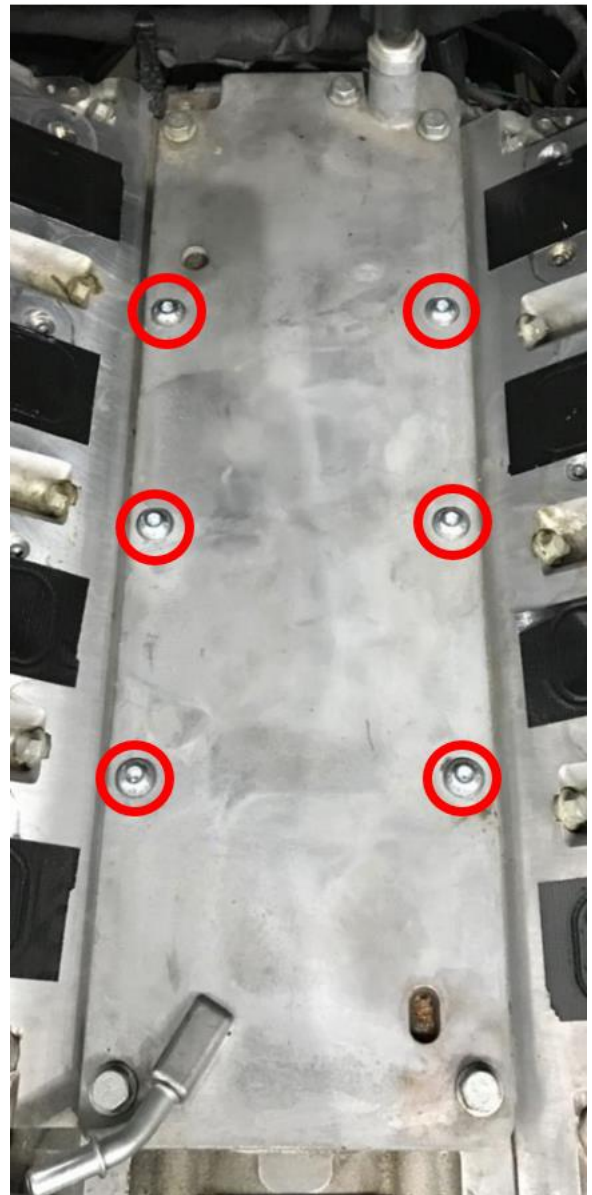

• **3) Prepare H2650i Supercharger**

- a. Sit the supercharger upside down.
- b. Place the included manifold gaskets on the ports.
- c. Using the 4 supplied blind rivets, fasten the manifold gaskets to the supercharger in the locations shown in Yellow. Ensure that the gasket is pulled flat onto the manifold surface and the head of the rivet is below the gasket face. Collect and discard the rivet pins so that they cannot accidentally enter the engine or supercharger.

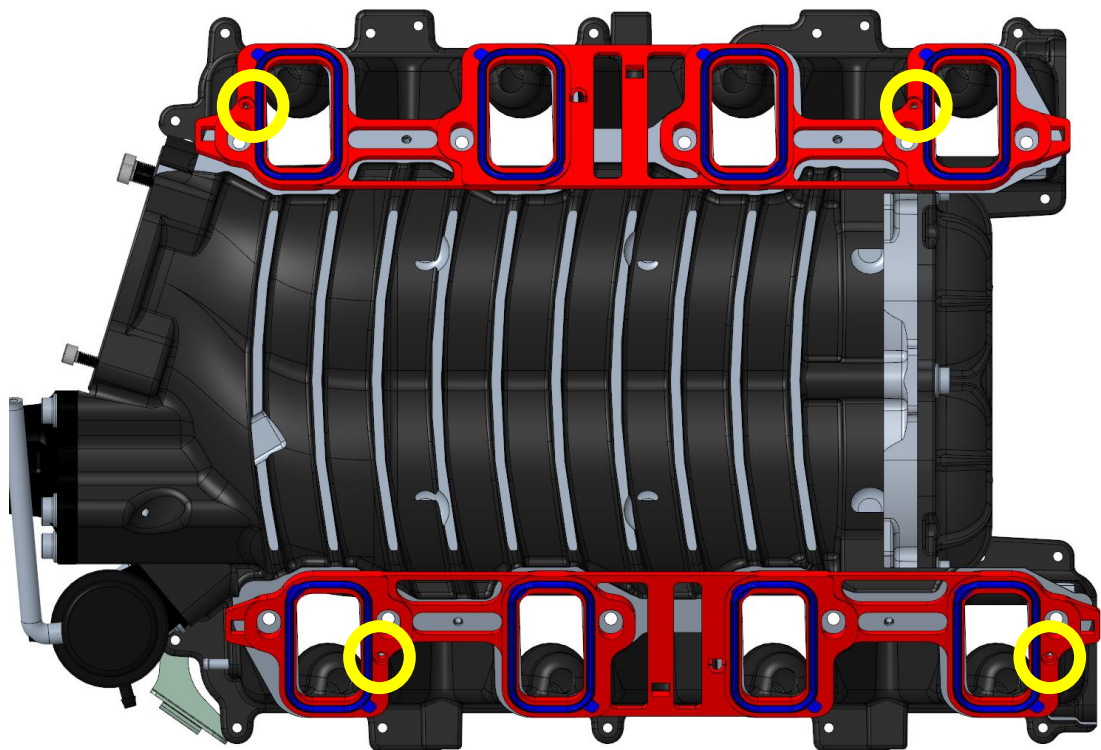
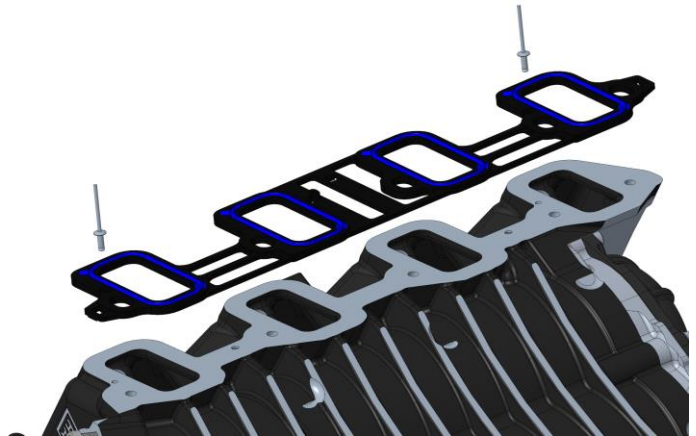

3) Fitting supercharger assembly

- a. Install supercharger manifold on engine
- b. Supercharger bolt torque sequence
 - First pass torque to 5Nm (44 lb-in)
 - Second pass torque to 10Nm (89 lb-in)

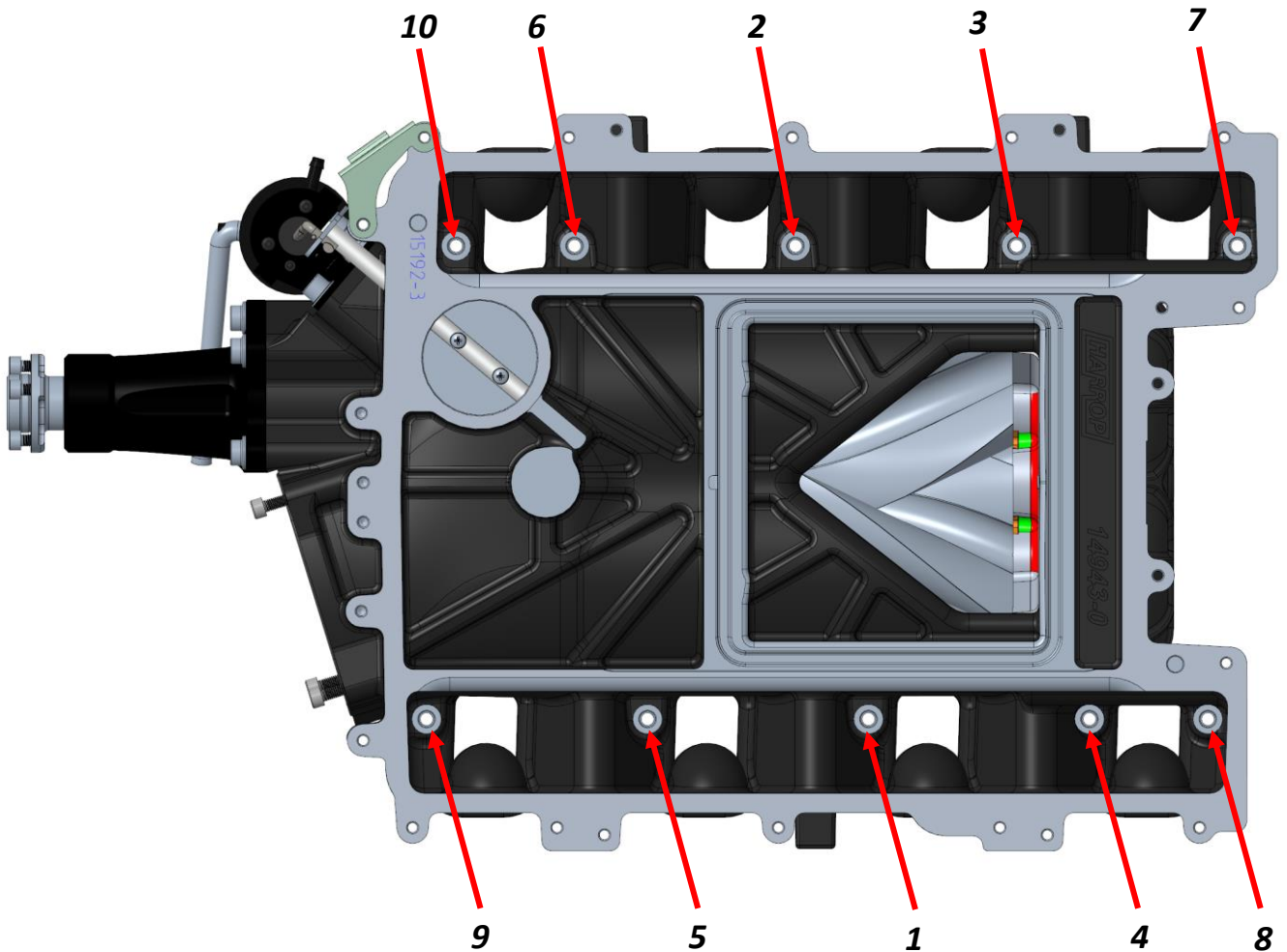

4) LSA Boost control solenoid

- a. Prior to the lid being bolted back on remove the boost control solenoid valve from the factory bracket
- b. Insert the valve into the new bracket supplied.
- c. Using the OEM solenoid hoses connect the solenoid valve fitting closest to the electrical connector to the manifold fitting located in the upper right front (Red)
- d. Connect the centre solenoid fitting from the valve to the by-pass actuator (Green) Once this has been connected it will mount as per image below with the existing lid screws.

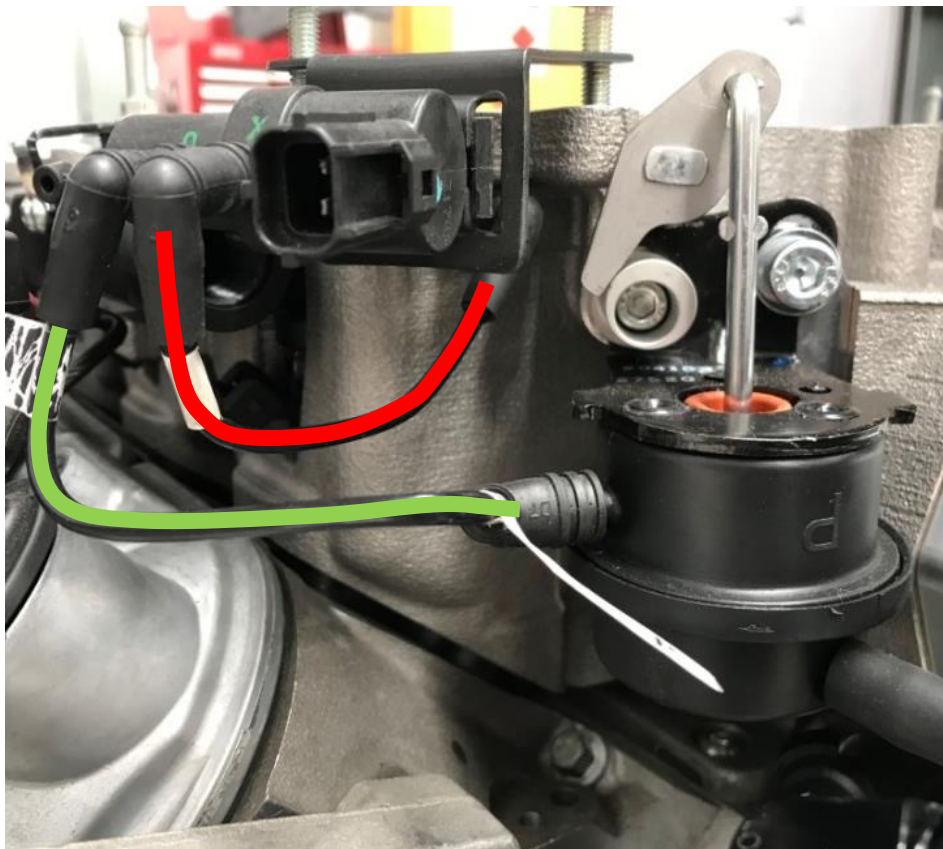

5) Bypass vacuum line connection

- a. Connect bypass vacuum line (shown in Green) to 7mm barb fitting throttle body adaptor
- b. The vacuum line connection applies to both LSA and non LSA vehicles

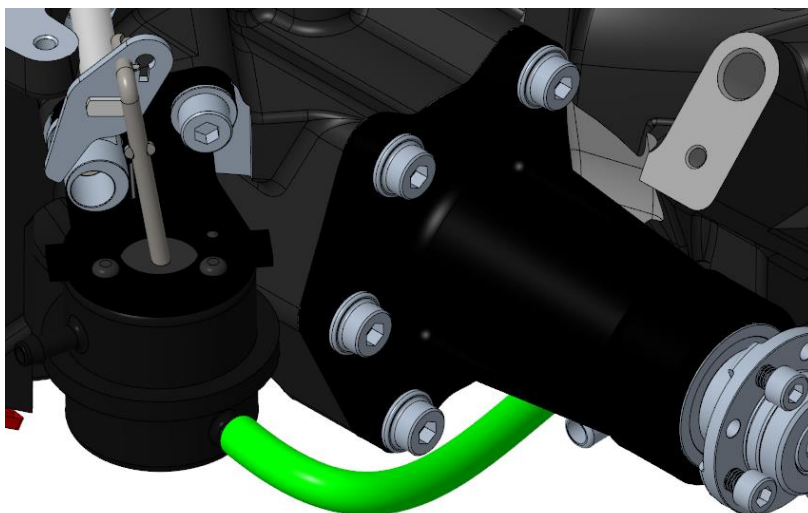
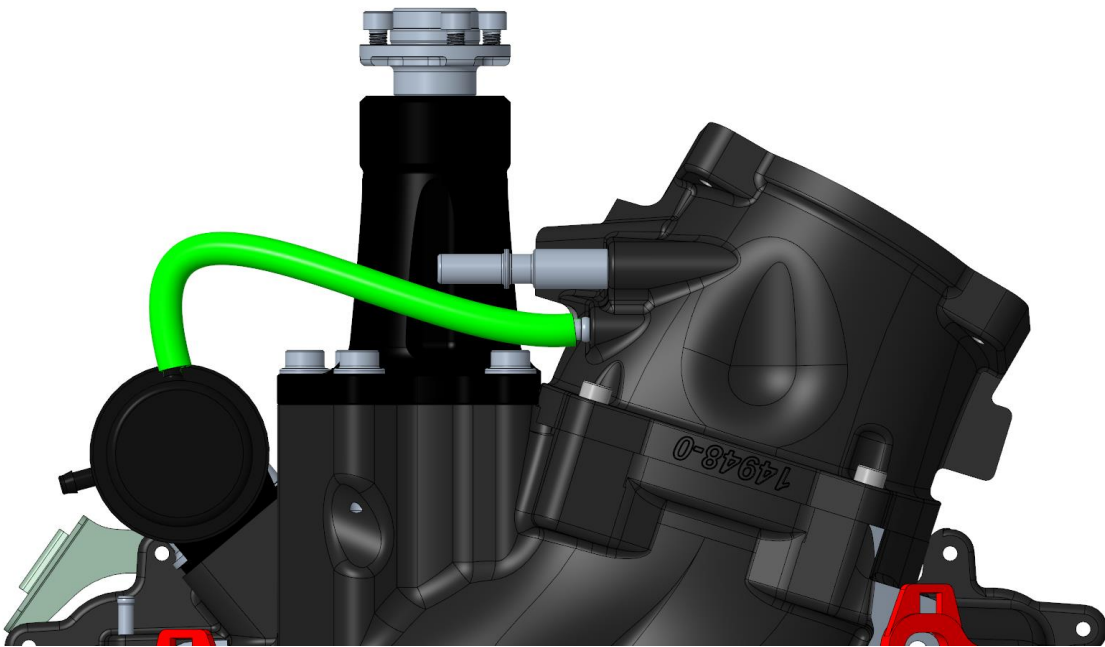

6) *Throttle body adaptor*

- a. Install the throttle body adaptor or 115 integrated throttle body to the supercharger using the supplied M6 cap screws (Yellow). Apply Loctite 243 (Blue) Torque to 12-14Nm

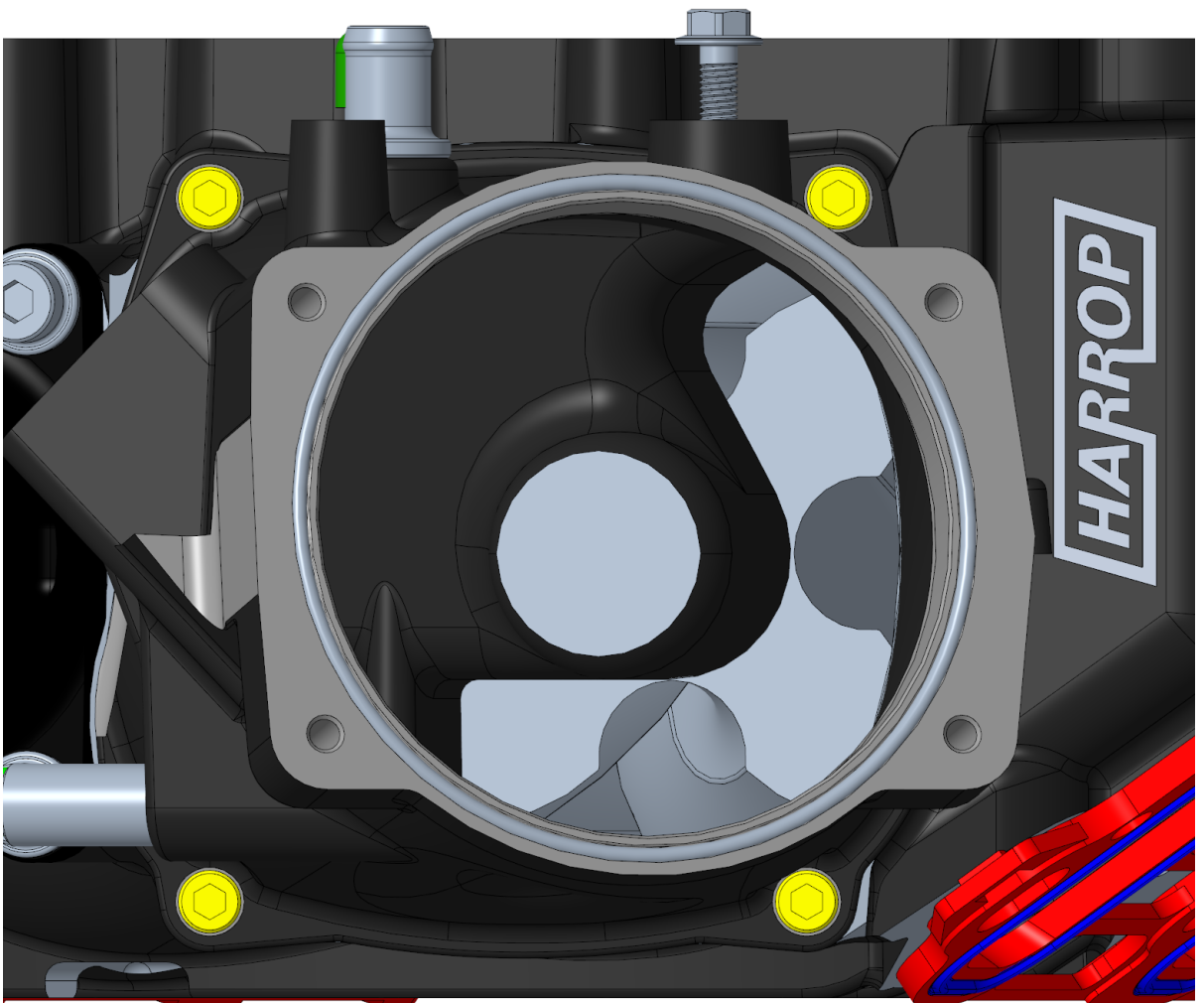

7) Pulley installation

- a. Remove supplied M6 pulley cap screws (Yellow)
- b. Install selected pulley reinstall cap screws. Bolts are Loctite pre-coated. Torque to 12-14Nm

