

MUSTANG SUPERCHARGER KIT

Extreme Performance. Ultimate Driveability.



OVERVIEW

The TVS2300 Supercharger is designed and manufactured by Harrop to OE standards leveraging our Ford supply program for the factory 'Miami V8' in Australia. Utilising the latest generation Eaton TVS supercharger technology, the system is exclusively designed for the Mustang 5.0L Coyote engine.

The front drive/front inlet design allows for a shorter less restrictive intake path allowing for improved air flow and superior performance. The integrated design and the latest intercooler technology provides optimal air distribution over the intercooler face.

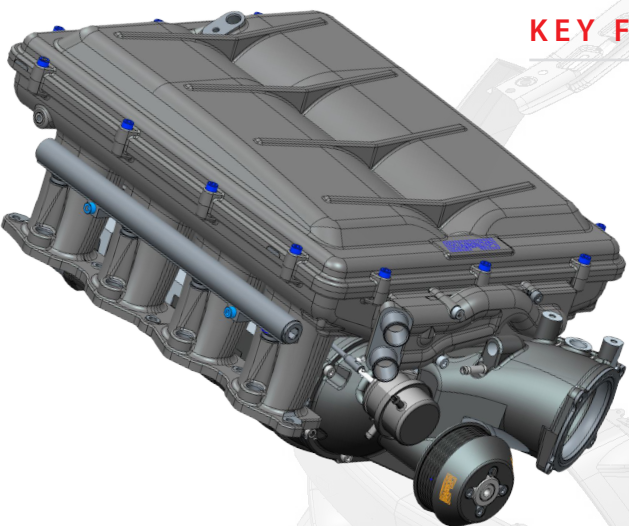

KEY FEATURES

- Harrop FDFI2300 rotor group
- Utilising the latest in Eaton TVS technology
- Latest high density fin, extruded tube intercooler core
- Inverted design for increased intercooler area
- Front Drive / Front Inlet for less restrictive intake path
- Triple pass coolant, Double pass charge air intercooling
- Retains all factory accessories
- Designed & Manufactured in Australia
- OE Quality & Fitment



Quality
ISO 9001

ENGINEERING PERFORMANCE SINCE 1955