



Installation Guide

TVS1900 Supercharger System

Toyota Landcruiser - LC200 - 4.6L 1UR-FE V8



ENGINEERING PERFORMANCE SINCE 1955

Important Information

Installing the supercharger indicates your acceptance of the responsibility and liability associated with the fitment and use of this product. Please ensure the owner and drivers of the supercharged vehicle are aware of their responsibilities and liabilities as indicated below.

Thank you for purchasing this supercharger which has been designed and made with pride. The owner and drivers of the enhanced vehicle must be aware that fitment of a supercharger may affect:

- The vehicle's factory warranty.
- Insurance cover and associated liabilities.
- Compatibility with emission and roadworthy certification.
- The validity of a driver's license for a supercharged vehicle.
- The handling & braking capability of the vehicle due to increased engine power & torque characteristics.
- The longevity of the engine.
- The vehicle will need to use premium unleaded fuel only - 98 RON (93 AKI).

It is the owner's/driver's responsibility to accept any consequences and liabilities of using the supercharger and any subsequent effect it may have. Harrop Engineering shall not be liable and shall be 'Held Harmless' for any direct and/or indirect/consequential losses, costs, damages, expenses, injuries or liabilities whatsoever incurred by the owner/driver of the vehicle or other parties arising from this supercharger, its installation and/or its operation. It is recommended that vehicles have completed 1,500 km and have been driven, serviced and maintained in accordance with the vehicle manufacturer's handbook before fitting a supercharger. An engine should be deemed reliable and have delivered all reasonable expectations in line with the vehicle manufacturer's specifications prior to fitting a supercharger.

Warranty

This supercharger is covered by a limited warranty on components and workmanship for a period of 36 months from the date of purchase, subject to the following:

- Installation must be completed by a qualified motor mechanic or technician who has undertaken appropriate training in fitting Harrop superchargers.
- The supercharger has not been modified or "overdriven" by fitting alternative drive pulleys.
- The supercharged vehicle has been tuned by an appropriately qualified and experienced technician.
- The supercharged vehicle has been driven in accordance with the conditions specified by the vehicle manufacturer's normal use of operation, driving care and vehicle service program.
- The supercharged vehicle has not been used for competitive racing.

No warranty shall apply where Harrop have determined improper fitment or handling, misuse in operation, neglect, or accident damage. Engine modifications made prior to or in conjunction with the supercharger fitment may invalidate the Harrop limited warranty. Any warranty claims must be made immediately & directly in writing to Harrop Engineering so that a determination can be made promptly. Involvement of a third party or an attempt to repair a perceived/actual fault may invalidate the warranty. To the extent of the law, the determination on any warranty claim & associated costs will be at the sole discretion of Harrop Engineering.

By installing the supercharger, you acknowledge that all conditions pertaining to this supercharger and its operation have been read, understood and accepted

TOYOTA 1UR-FE TVS1900 SUPERCHARGER

Installation Guide



For 65 years Harrop Engineering has been at the forefront of designing, developing and manufacturing precision performance components. Today our innovative and logical approach is applied to low volume automotive OEMs and the performance aftermarket through a dedicated team of 65 staff. Core performance products include Superchargers, Engine Components, Brakes, Differentials and we are also the exclusive Australian Distributor for Forgeline Motorsport Wheels.

Harrop are also the preferred supplier of Eaton Supercharger and Traction Control technology including dual branded product designed and manufactured in-house. There are currently over 4,000 components in our portfolio and this is growing daily as we continually develop more Harrop Performance Products.

Our high-profile car manufacturing customers have included Holden, HSV, FPV, Ford, Roush, Toyota, TRD and Lotus. We also supply to race teams from categories including F1, NASCAR and V8 Supercars and an extensive range of drag, circuit and off-road competitors. Just as importantly, a large portion of our customers are performance enthusiasts and weekend warriors who are highly passionate about their ride.

Please take a moment to review the following pages and learn why Harrop is the first choice in Superchargers. Thank you for choosing Harrop and enjoy your Harrop Enhanced ride.

- Team **HARROP**



This document is meant only as a guide, as any vehicle modification should be completed by a certified technician who has the relevant experience and equipment to be competent of a safe and effective supercharger installation.

ENGINEERING PERFORMANCE SINCE 1955

TOYOTA 1UR-FE TVS1900 SUPERCHARGER

Installation Guide



The Harrop TVS1900 Supercharger Tuner kit has been developed for Toyota 1UR-FE V8 engines. Suitable for Land-Cruiser 200 vehicles with the 4.6 Litre V8 1UR-FE engine.

The following part numbers should be referenced when ordering so the correct kit is supplied.

Variants:

Harrop Part Number	MY2012 Toyota Landcruiser 200 series - 1URFE 4.6L V8
99-KSM57K39	S/Chrgr Kit FDFI1900 Toyota 1UR



Note that this is a Tuner kit; a full kit will be available once an Executive Order (EO) number from CARB has been obtained. For off-road use only in North America without EO number.

ENGINEERING PERFORMANCE SINCE 1955

Contents

Preparation	5
1) Install Harrop intercooler radiator	6
2) Installation of the Intercooler Pump Wiring	10
3) Removal of Toyota Intake Manifold.....	12
4) Removal of Toyota Coolant crossover pipe	15
5) Installation of idler bracket and crossover pipe	16
6) Installation of the Harrop Supercharger	18
7) Install Ancillary hoses and brackets	20
8) Finalise installation.....	22
9) Initial engine start and Calibration.....	22

Preparation

Ensure the fuel tank contains 98-RON (93-AKI) fuel.

RHS of vehicle is from the driver's perspective when in the driving position.

Allow the engine to cool before starting installation.

Disconnect and remove the battery.

Remove the under tray.

Drain the radiator by opening the drain cock on the lower corner of the radiator.



1. Install Harrop intercooler radiator

- a) Remove the front Bumper-bar/Grille assembly.
- b) Un-clip the horn looms and remove 2x Horns. Unclip the ambient air temperature sensor clip from the centre strut.
- c) Dis-connect the electric fan loom plug and remove the top M6 screw securing the fan to the front top panel.
- d) Tilt the fan forward and lift up and out of the vehicle.
- e) Remove the plastic cap from the top screw on the centre strut, and remove the screw. Remove the 2nd top, lower and middle screws to remove the strut.

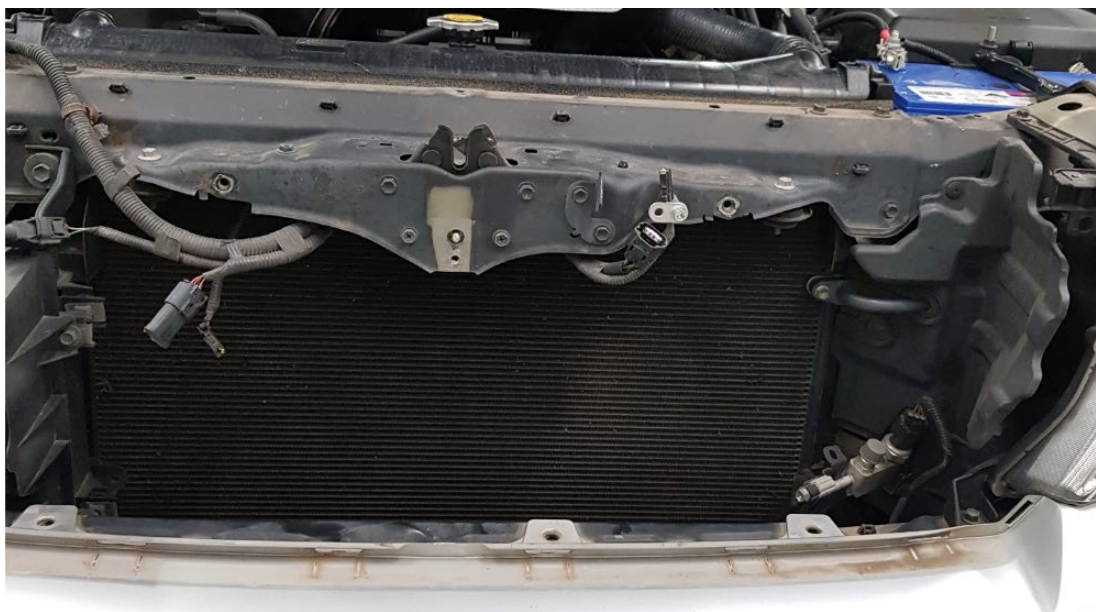
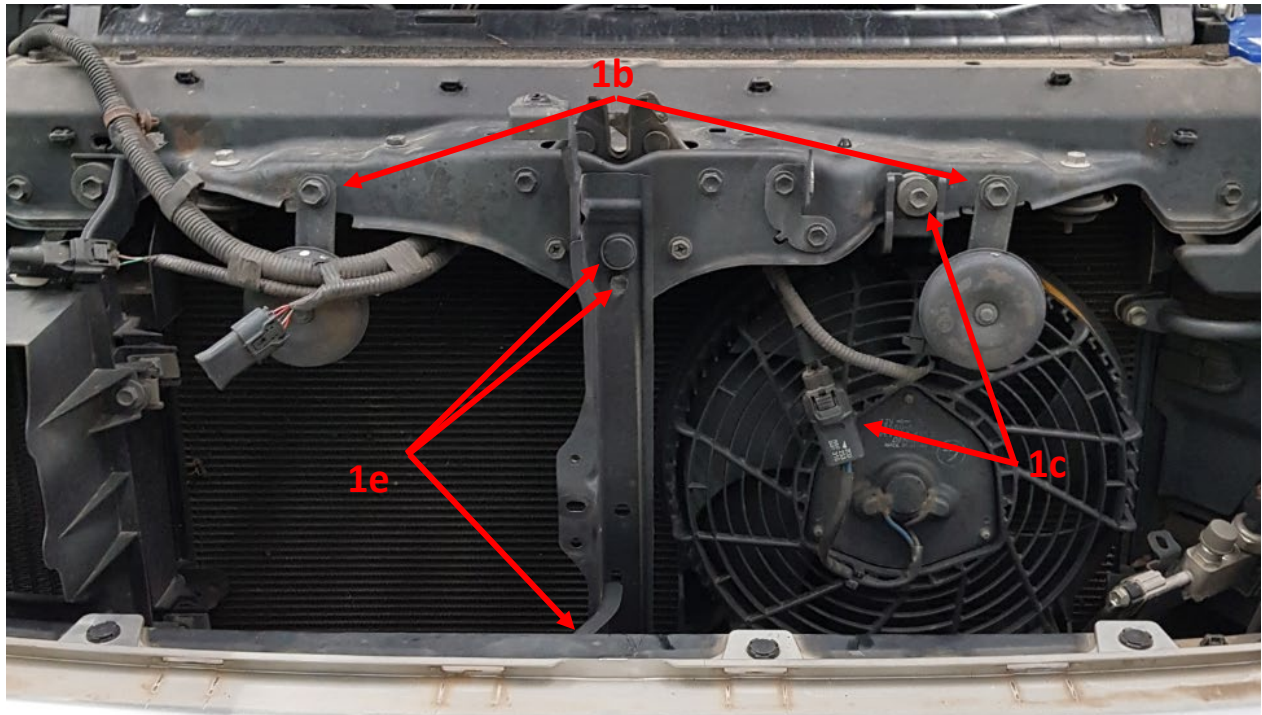

- f) Assemble the Harrop Intercooler Radiator Top Brackets and Pump bracket

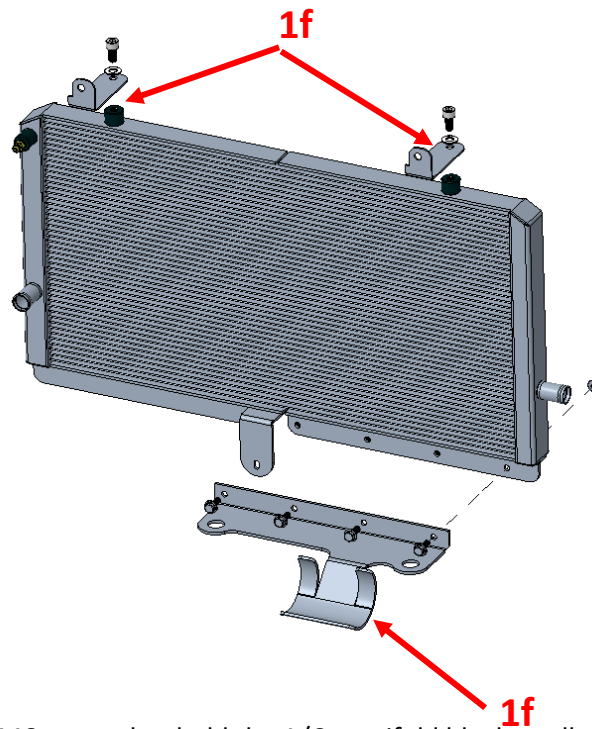

- g) Temporarily remove the M6 screw that hold the A/C manifold block to allow some movement.
h) Install the Harrop Intercooler Radiator in front of the A/C condenser.
i) Secure the top 2x brackets with the original horn mounting screws.
j) The lower bracket will be secured in a later step (see step 1n).

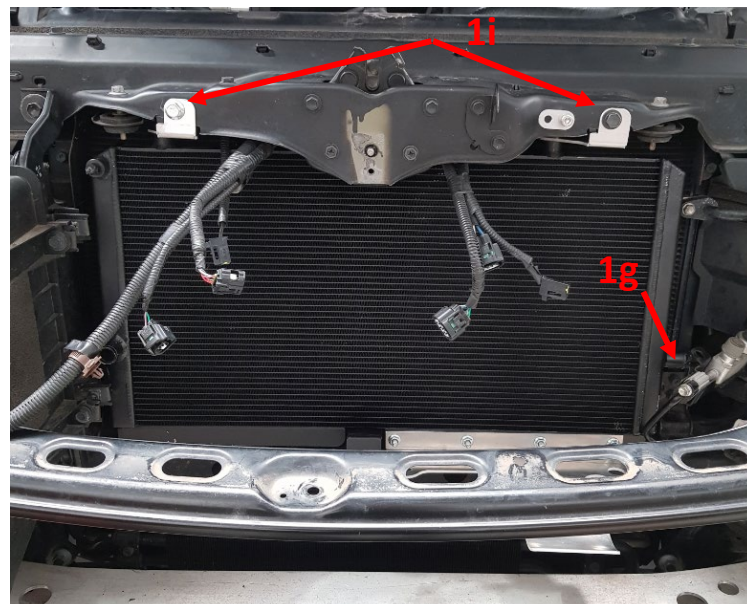

- k) Re-tighten the M6 screw that holds the A/C Fill block.
l) Re-install the electric fan by inserting the rubber feet into the 2x holes in the lower bracket.
m) Use the supplied top adaptor bracket, spacer, M6 x 40 screw and M6 nut to secure the fan top mount.

ENGINEERING PERFORMANCE SINCE 1955

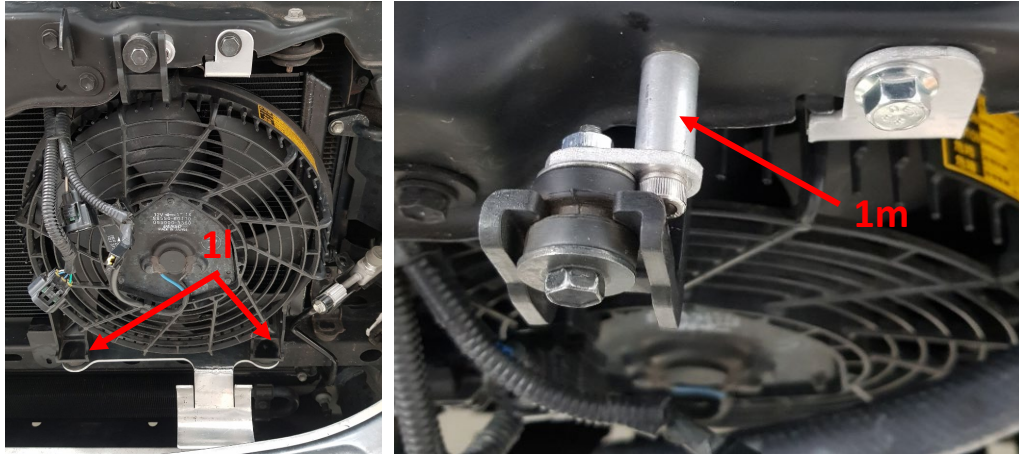

- n) Re-install the Centre strut and re-connect the Ambient air temp sensor. Secure the Intercooler Radiator lower bracket between the Centre strut and the cross-member using the original screw.
- o) Re-install the horns one at a time to the original position.
- p) Re-connect all loom plugs.
- q) Install the Intercooler Pump on the bracket provided and secure with 2x hose clamps. Orient the pump with the outlet pointing slightly forward of vertical to allow the hose to pass in front of the electric fan.

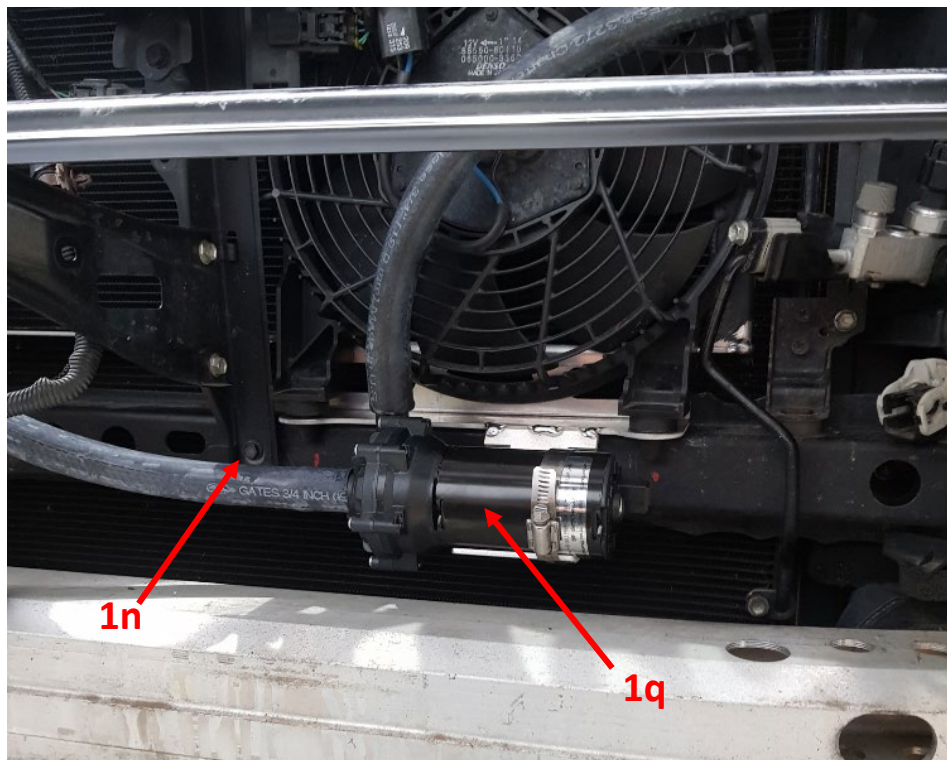

Installation Guide

- r) Connect the $\frac{3}{4}$ " x 500mm long pump inlet hose between the pump inlet (horizontal) and the Intercooler Radiator RHS pipe. Secure with hose clamps.
- s) Connect and run the $\frac{3}{4}$ " x 2000mm long Radiator inlet hose under the LH A/C Condenser pipe and through the gap in into the engine bay. Secure the Radiator inlet with a hose clamp. Run the end with the U-bend into the engine bay for connection later (step 6i).

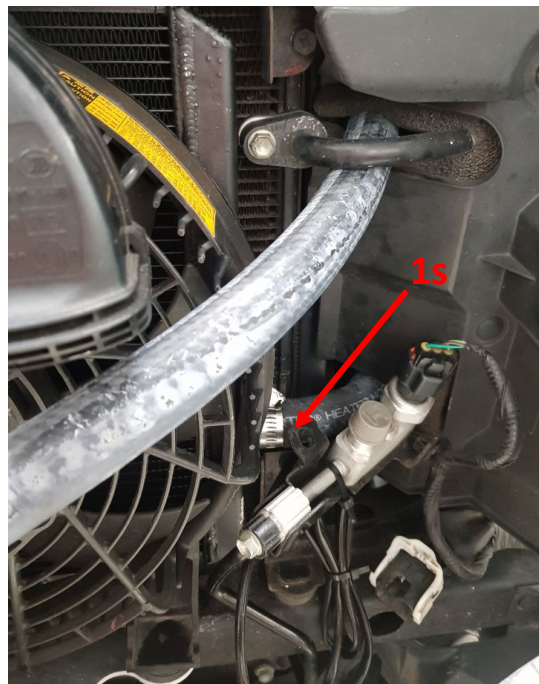
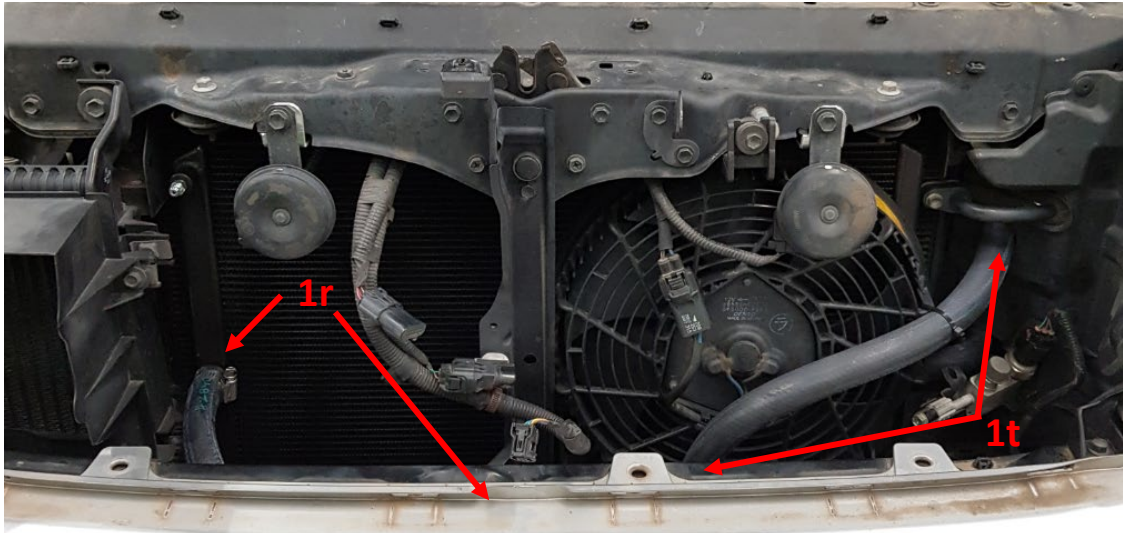

- t) Connect the $\frac{3}{4}$ " x 1300 long pump outlet hose to the lower LHS of the Intercooler radiator and run through the gap behind the A/C Fill block and into the engine bay. Secure the pump outlet with a hose clamp. Run the end with the 90-degree bend into the engine bay for connection in a later step (step 6h)

- u) Using the supplied cable ties, ensure the Intercooler hoses are secure and cannot come into contact with any moving parts.

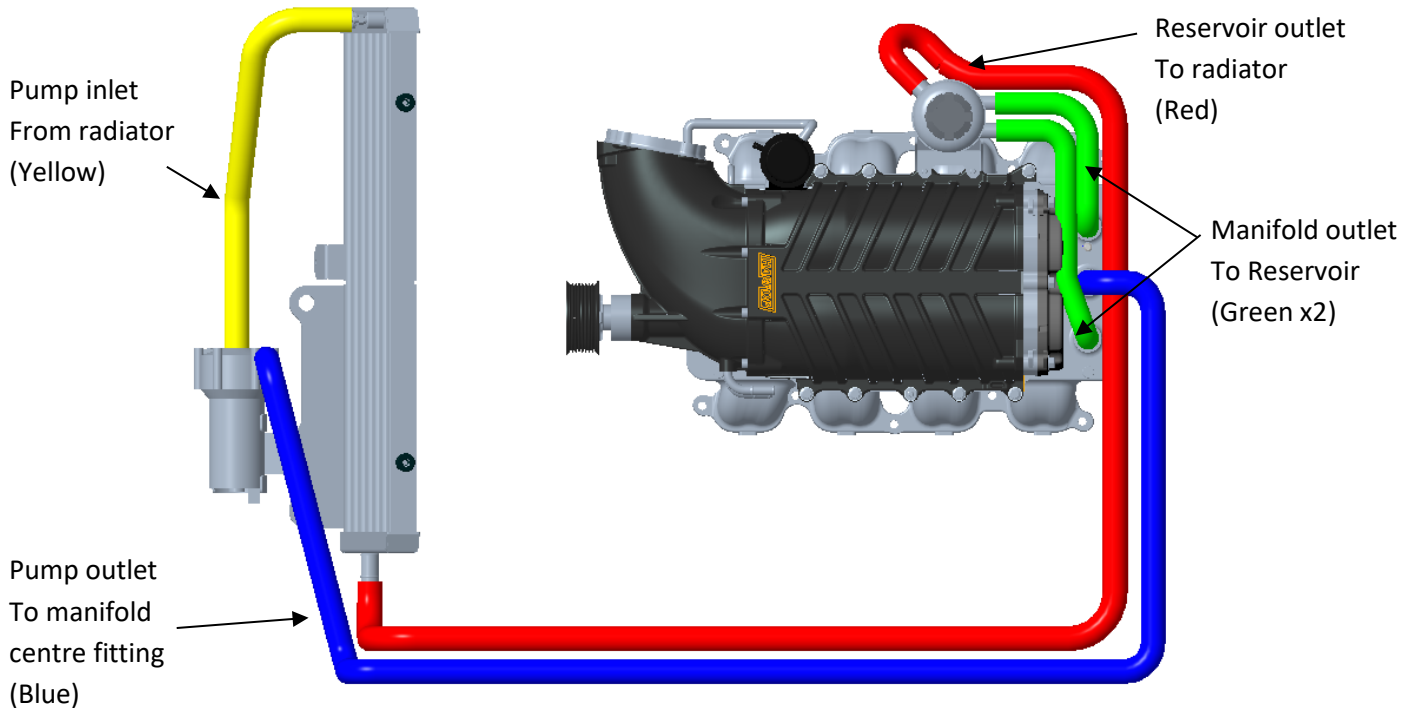

Intercooler Coolant diagram – not to scale

Hoses shown in colour for illustration only

2) Installation of the Intercooler Pump Wiring

- a) Connect the supplied intercooler pump loom to the pump and run the loom along the lateral chassis member and cable tie it as necessary to secure it. Allow some slack in the loom near the pump plug to enable easier disconnection if required.
- b) On the LHS of the intercooler radiator, there is enough space to pass the loom through the LH infill panel without cutting it. Route the loom toward the fuse box, located behind the battery.
- c) Remove the fuse box lid.
- d) The intercooler pump loom relay is mounted on the outside of the fuse box, as shown in the image below. Position the relay and mark the centre of the mounting hole. Drill a $\varnothing 5.5-6.0\text{mm}$ hole and secure the relay using the supplied M5 x16 Button head screw and nut. Make sure the relay is mounted low enough so the fuse box lid can still close.

TOYOTA 1UR-FE TVS1900 SUPERCHARGER

Installation Guide

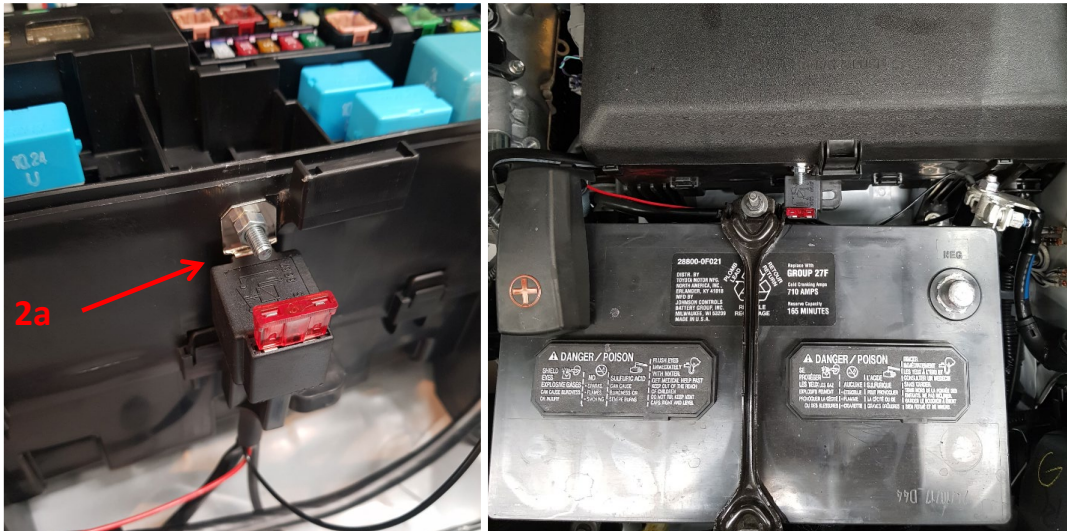

- e) Connect the red (positive) wire directly to the positive battery terminal clamp.
- f) Connect the black (negative) wire directly to the negative battery terminal clamp.
- g) Run the fuse break-out lead to the inside of the fuse box directly behind the negative battery terminal, remove the IGN 10A (ignition) fuse and replace with the supplied fuse break-out.
- h) Replace the fuse box lid ensuring the intercooler pump loom is not pinched.
- i) Cable tie the loom to secure it where necessary.

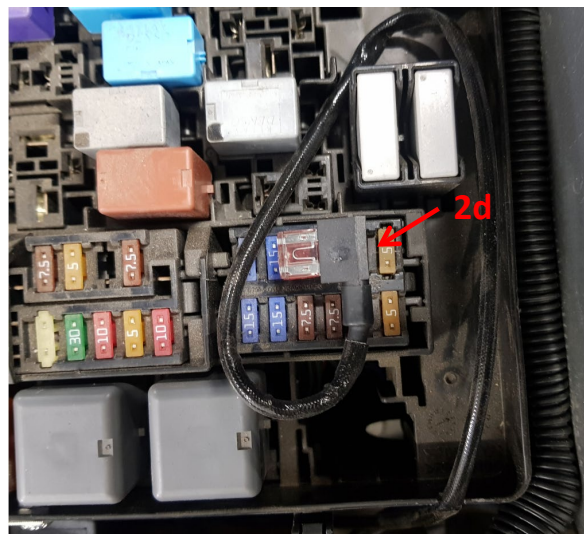

ENGINEERING PERFORMANCE SINCE 1955

3) Removal of Toyota Intake Manifold

- a) Remove plastic engine cover

Dis-connect/unplug the following wiring:

- b) ETC (throttle body)
- c) Coolant temperature sensor (coolant cross-over pipe beside top radiator hose on engine front)
- d) Fuel purge valve and ACIS VSV (LHS of OE manifold, behind the fuel purge valve). Tape up the ACIS VSV plug as it is not re-used.

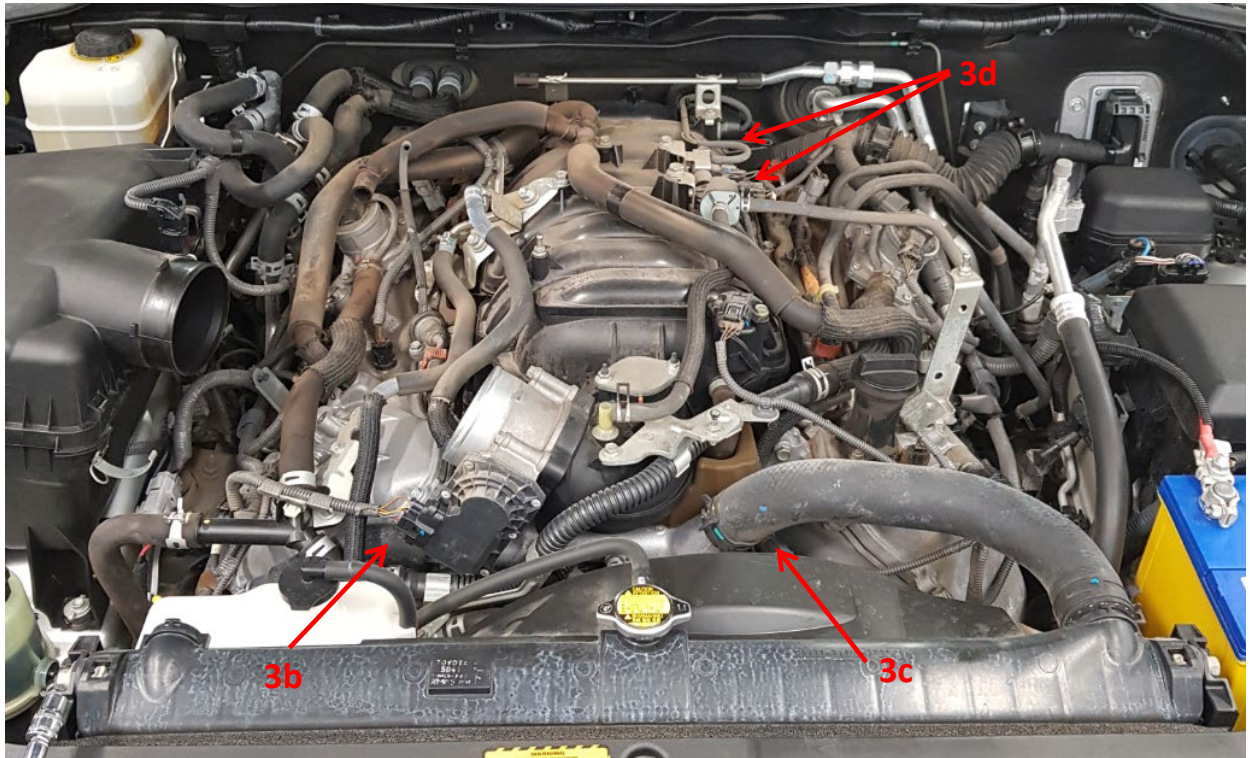

Dis-connect the following components:

- e) Fuel pressure regulator reference and crankcase ventilation tubes from the Throttle intake tube. Remove the Throttle tube with resonance chamber. These are not re-used.
- f) Crankcase ventilation hoses from LH and RH rocker covers. Un-screw the clip and tee-piece from the manifold, and completely remove them from the engine. Only the T-piece will be re-used.
- g) Fuel purge valve from the manifold LHS.
- h) Fuel purge valve hose from the throttle end of the manifold.
- i) PCV valve hose from the front of the manifold.
- j) Remove the engine Radiator top hose completely.
- k) Dis-connect the coolant hoses from under the throttle body, and thermostat housing.
- l) Wiring loom bracket from the RHS rear of the manifold.

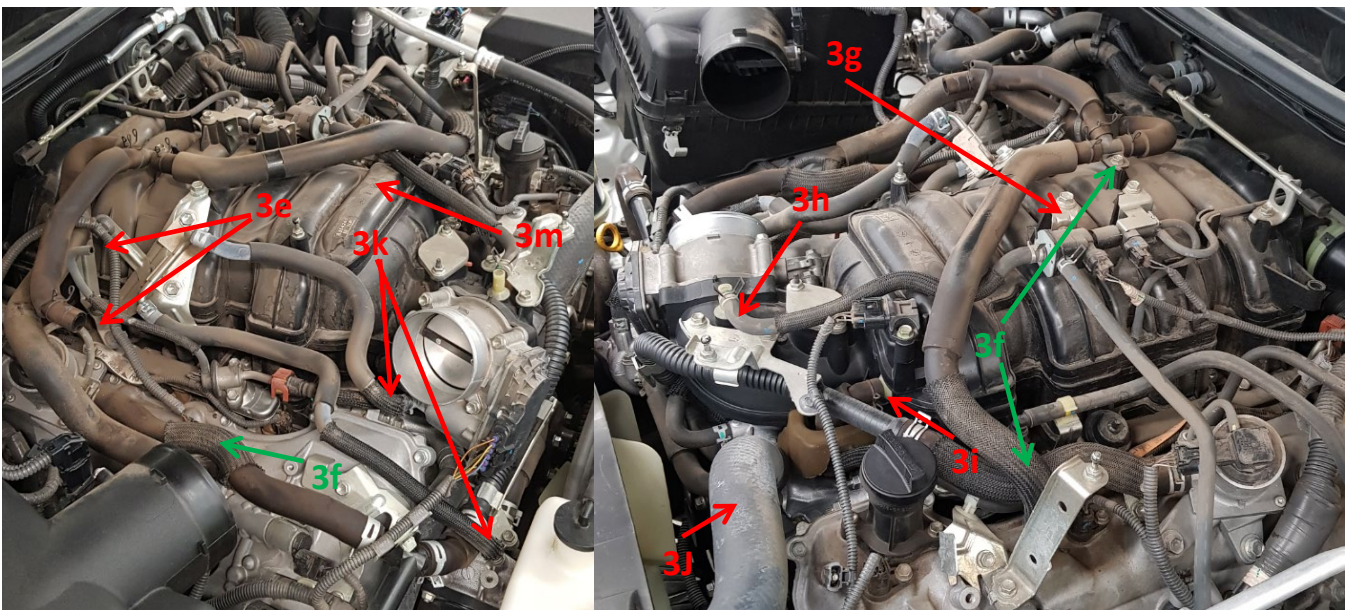

- m) Remove the OE intake manifold, discarding the foam inserts at either side.
 - i) It is necessary to un-clip the wiring loom at the rear of the manifold before it can be removed.
 - ii) Remove the M6 screw that secures the OE fuel crossover line at the back of the manifold.
 - iii) Apply suitable tape over cylinder head ports to prevent foreign material from entering.
 - iv) Remove the 2x foam insulation from the engine valley.
- n) Replace the m6 bolt securing the water pipe in the valley with the provided M6x20 Button head screw.
- o) Replace the hose adjacent to this screw with the supplied 1/2" x 600 long heater hose. Re-use the hose clamp. Run this hose forward towards the radiator hose location for connection later (step 5k).
- p) Remove the PCV hose from the valley and connect one end of the supplied 3/8" x 700 long PCV hose to the PCV valve. Secure with a hose clamp. The other end will be connected in a later step (step 7b).

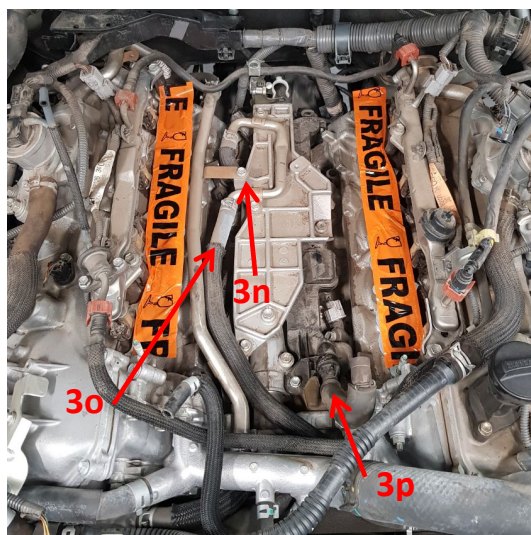
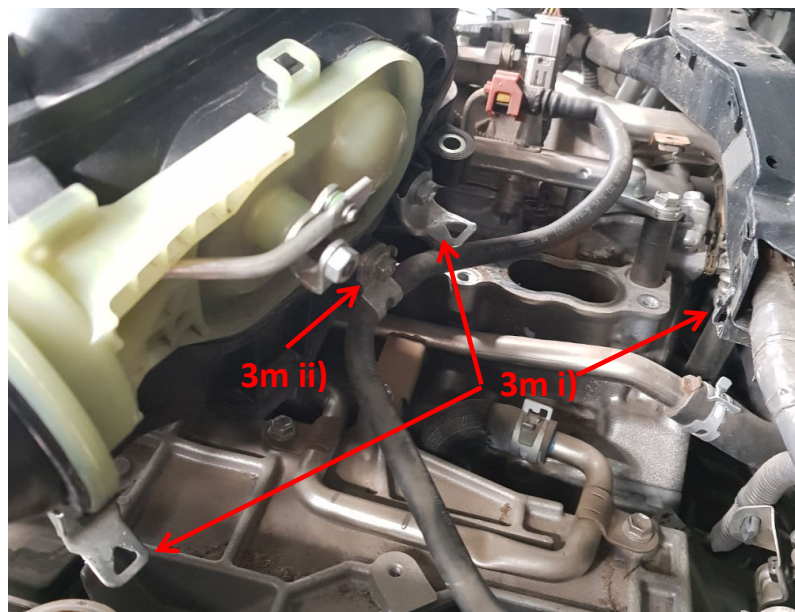

4) Removal of Toyota Coolant crossover pipe

Dis-connect the following components:

- a) Thermostat housing to Coolant cross-over hose. Disconnect both ends and discard.

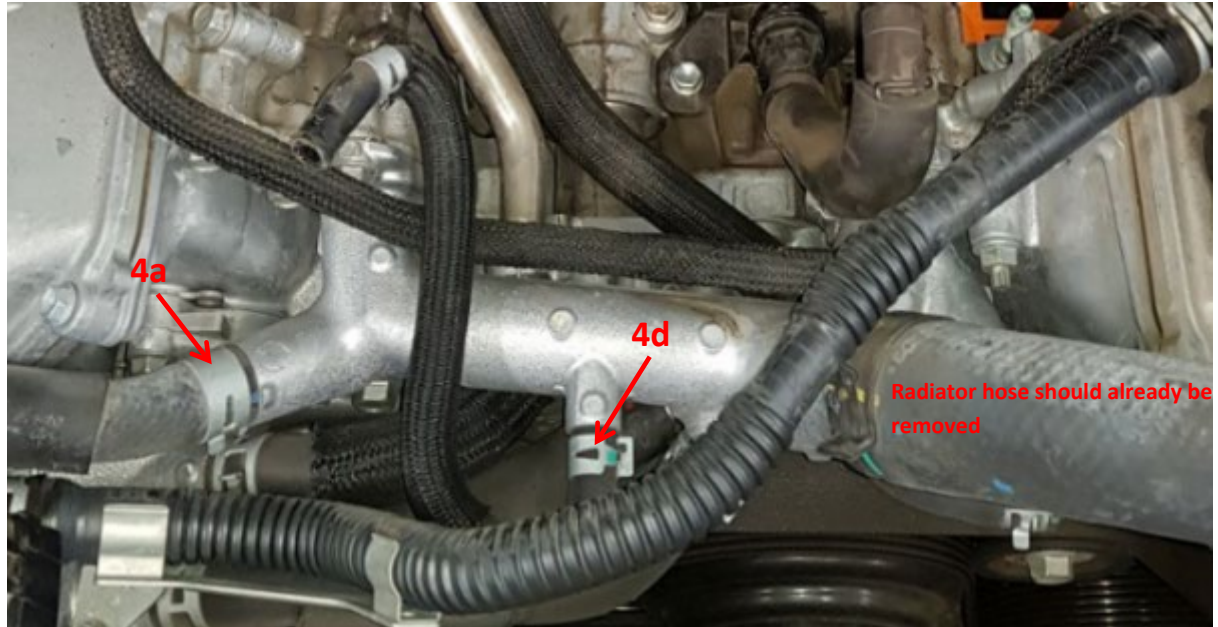

- b) Remove the Toyota Coolant cross-over pipe from the engine. The gaskets and nuts will be re-used.
- c) Remove the coolant temperature sensor from the Toyota Coolant cross-over pipe. This will be re-used.
- d) Remove the throttle body coolant hose from the crossover pipe – this will be re-used. See step 5l.

5) Installation of idler bracket and crossover pipe

Disconnect or remove the following components:

- Toyota FEAD belt. Turn the tensioner anti-clockwise with a 14mm socket until there is enough slack to remove the belt.
- Remove the small grooved pulley off the front LHS of the engine and then fit the 8mm Idler spacer in the kit and fit the supplied idler pulley. Re-use the factory bolt.
- The stainless-steel pipe adjacent to the pulley replaced in step 5b needs to be bent slightly to allow clearance for the new supercharger belt. Use a piece of bar or similar to help you bend this pipe up and across so it will clear the supercharger drive belt. Hold the bottom of the pipe while you do this.



- Remove the three bolts shown below to allow fitment of the supplied idler bracket.
- Install the idler bracket (minus the pulley) to the engine using the three screws provided.

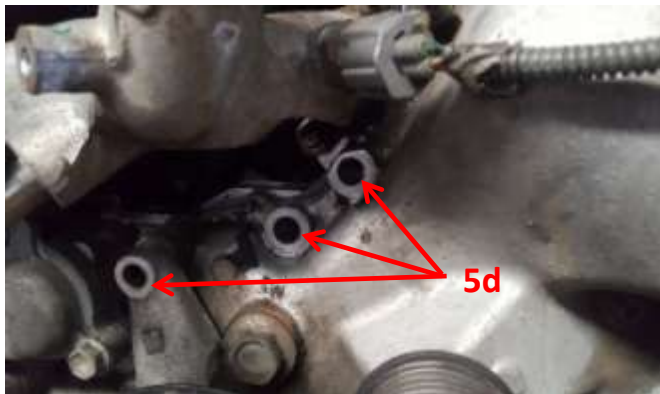

Installation Guide

- f) After tightening these three screws to 16Nm, install the pulley and tighten the screw to 16Nm.
- g) Install the supplied water crossover pipe to the engine using the original gasket and nuts. Use a suitable sealant on the gaskets when installing. It may be necessary to bend some of the hard coolant lines slightly so they don't interfere with the crossover pipe or idler bracket.

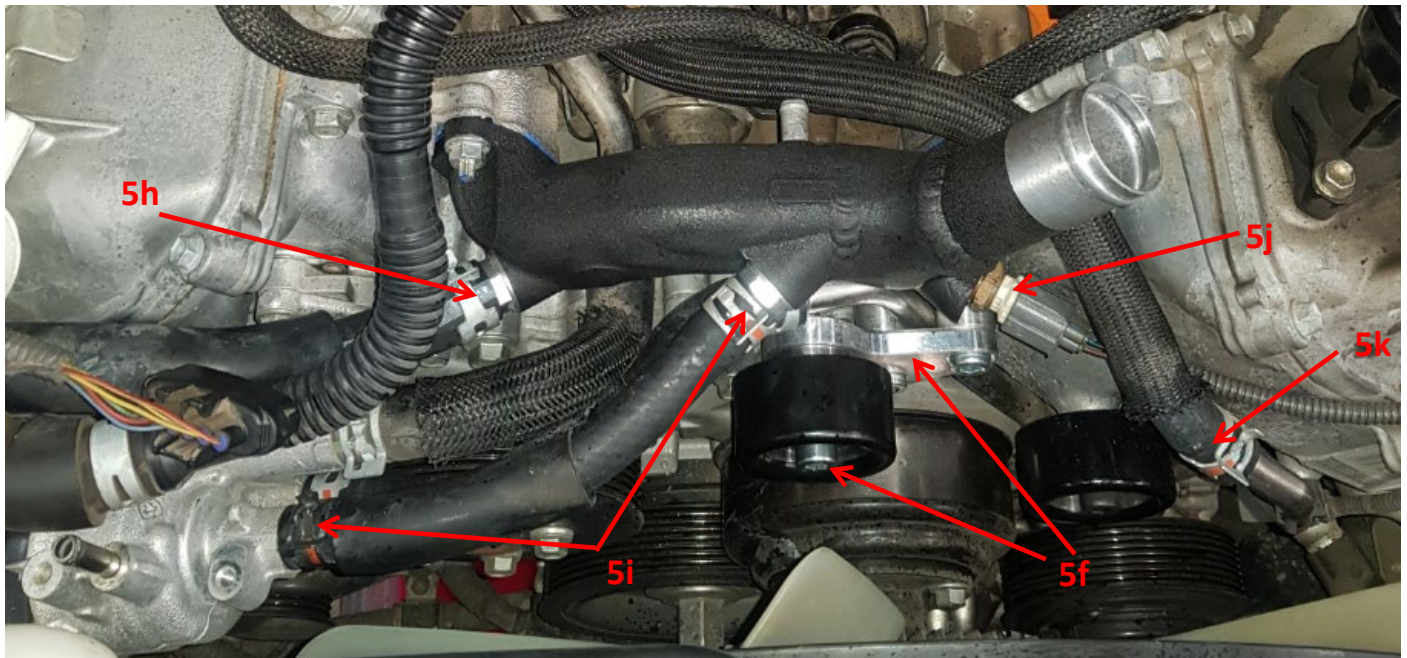

- h) Install the supplied 5/8" x 300 long hose between the pipe on the RH timing cover and the RH barb of the crossover pipe.
- i) Trim if necessary and fit the original hose between the thermostat housing and the front of the crossover pipe.
- j) Transfer the coolant temp sender to the new crossover pipe and plug the loom in.
- k) Connect the free end of the 1/2" x 600 long (refer to step 3o) heater hose to the coolant hard line that was bent in step 5c. Re-use the flexible hose shielding from the original hose.
- l) Attach the throttle body coolant hose removed at step 4d to the barb at the front of the crossover pipe. The other end will be connected in a later step (step 7d).
- m) Re-install the engine top radiator hose.

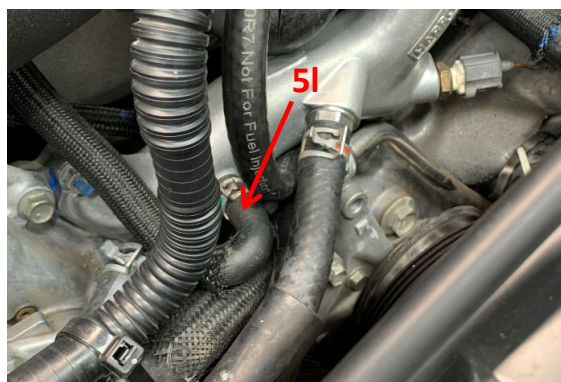

6) Installation of the Harrop Supercharger

- Remove the masking tape from the inlet ports and ensure the head faces are clean, dry and free from foreign material.
- Remove the O-ring from the original plastic intake manifold and fit them to the Supercharger manifold and apply a small amount of rubber grease. Run the PCV hose toward the front of the engine.
- Lower the Supercharger/manifold assembly into position. This is a heavy lift – utilise a suitable hoist.
- Tighten down the manifold using the 2x original nuts on the front studs, and the 8x supplied screws.
- Install the supplied Supercharger belt to the original FEAD, but route the belt over the supercharger pulley according to the following diagram:

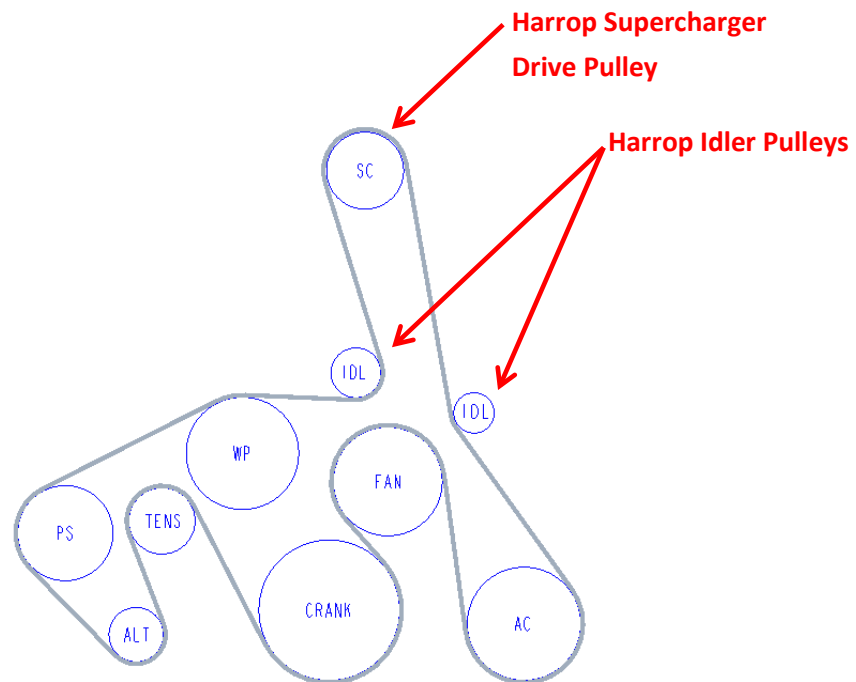

- Swap the OE MAP sensor from the original manifold to the front centre of the Supercharger manifold.
- Install the original Throttle Body to the Supercharger inlet using the original M6 screws. The electrical connector should be at the front and Vertical. Ensure the supplied O-ring is in position. Torque screws to 10-12Nm. Plug in the throttle electrical connector.



- h) Connect the free end of the 1300 long heater hose that is connected to the intercooler pump outlet to the rear of the supercharger manifold, centre fitting. Secure with hose clamp. Refer to step 1s.
- i) Find the 2000 long Radiator hose with a U-bend on the free end that is connected to the intercooler radiator inlet (LHS). Connect it to the Reservoir outlet on the RHS of the Supercharger. Refer to step 1t.

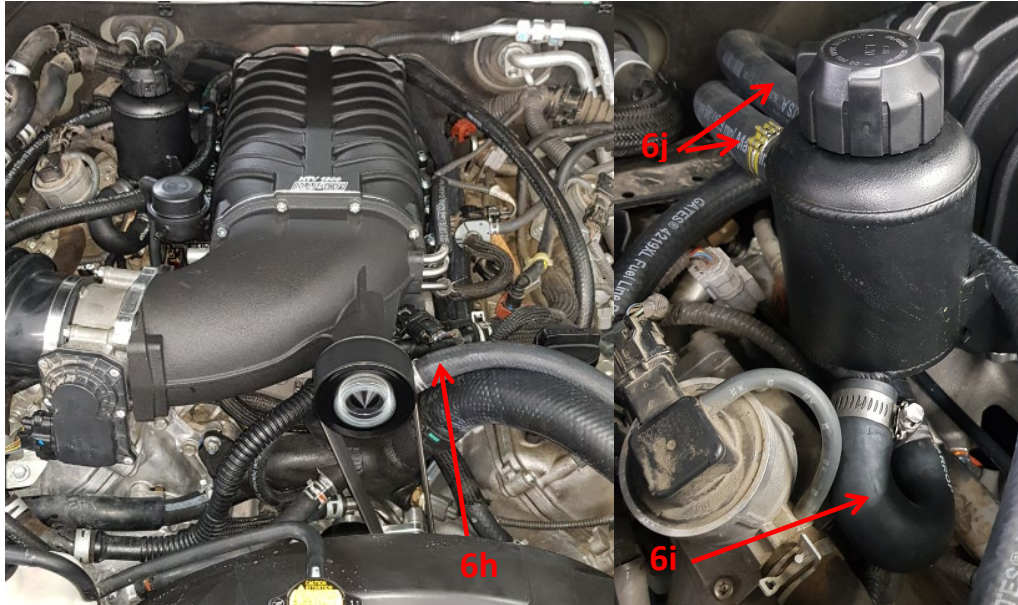

- j) Connect the supplied intercooler outlet hoses to the reservoir inlet (2x 1/2" hoses) and the supercharger manifold.
- k) Using the supplied cable ties and hose clamps, ensure the Intercooler hoses are secure and cannot come into contact with the supercharger drive belt or any pulleys.

7) Install Ancillary hoses and brackets

- Connect the original EVAP solenoid Vacuum line to the bottom elbow on the LHS of the Supercharger inlet cover. Using the original bracket, secure the EVAP solenoid to the supercharger manifold.
- Connect the free end of the supplied 3/8 X 700 long PCV hose to the $\varnothing 10$ hose barb on the LHS of the supercharger inlet cover. Refer to step 3o.
- Connect the original Throttle body coolant hose from the thermostat housing to a hose tail on the Throttle body.
- Connect the free end of the 8.0mm x 650mm coolant hose (coming out from the valley. See step 5l) to the other hose tail on the Throttle body.

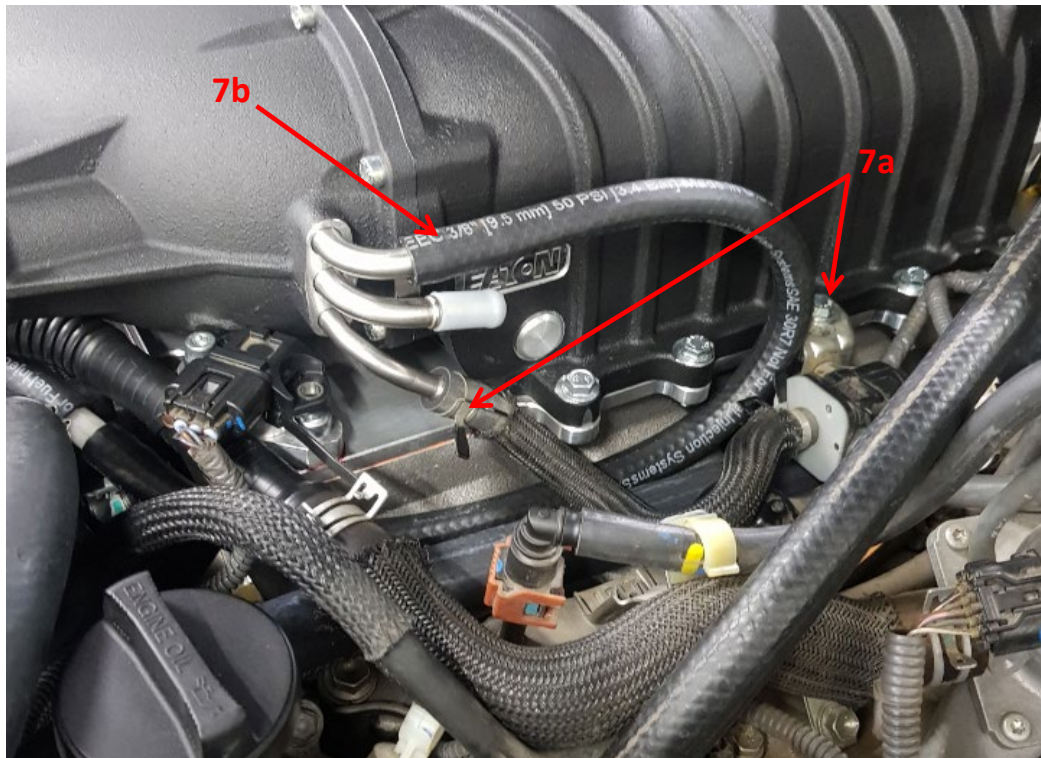

- Secure all Hose connections with the original clamps.



- f) Temporarily un-clip the air-box lid and install the Harrop intake boot between the original air-box and the throttle body. Re-use the hose clamps from the Toyota intake boot. The hose barb should point to the rear of the vehicle. Rotate the intake boot to align with the throttle and airbox. Re-clip the air-box lid into place.
- g) Using the OEM crankcase ventilation T-piece (refer to step 3f), connect the centre branch to the supplied $\frac{1}{2}$ " x 430 long PCV hose. Connect the other end of this hose to the intake boot using the supplied connector.
- h) Attach one end of the supplied 480mm long $\frac{1}{2}$ " vacuum hose to the RH facing branch of the T-piece, and the other end to the RH Rocker cover.
- i) Using the remaining 750mm long $\frac{1}{2}$ " vacuum hose, connect between the LH facing branch of the T-piece and the LH Rocker cover.
- j) Install the supplied $\frac{5}{32}$ " x 750 long vacuum hose between the fuel pressure regulator (remove existing hose) and the elbow at the rear RHS of the supercharger manifold.

8) Finalise installation

- a) Re-fill engine radiator with Genuine Toyota coolant, according to the vehicle owner's manual.
- b) Initial Intercooler system fill. Coolant to be used is either Ford WSS-M97B44-D and/or GMW3420, mixed with distilled or deionised water in a 50% concentrate. **Note filling with a con-compliant coolant will void warranty.** Fill via the intercooler reservoir, allowing time for the coolant to fill down to the front mount radiator. The ideal level is 25mm below the top of the reservoir with the cap removed. Use the bleed screw on the intercooler radiator to allow air to escape during filling.



- c) Re-fit under tray.
- d) Re-fuel the vehicle with 98-RON (93-AKI) minimum fuel.
- e) Install and Reconnect battery.
- f) Turn the ignition on without starting the engine. The intercooler pump should be running. Allow 1-2 minutes for coolant to circulate and switch the ignition off. Re-bleed the intercooler radiator and top-up the coolant level.

9) Initial engine start and Calibration

Do not place any load or subject the engine to high speeds until ECU calibration has been performed, if required. It is the installer's responsibility to ensure all coolant connections are leak free, all electrical connections are sound and proper procedures have been followed during installation.

- a) Start the engine and allow to idle only. Check that the supercharger belt is running smoothly and is correctly aligned on all pulleys.
- b) Allow the engine to reach normal operating temperature, then switch off the engine and allow to cool. Re-check the Intercooler reservoir level and the engine radiator level. Check for any leaks.
- c) Calibrate the ECU for the new supercharged induction system.